

# DOUBLE-RAIL TYPE HOIST WITH MOTOR-DRIVEN TROLLEY

WIRE  
HOIST

Ordinary Hoist

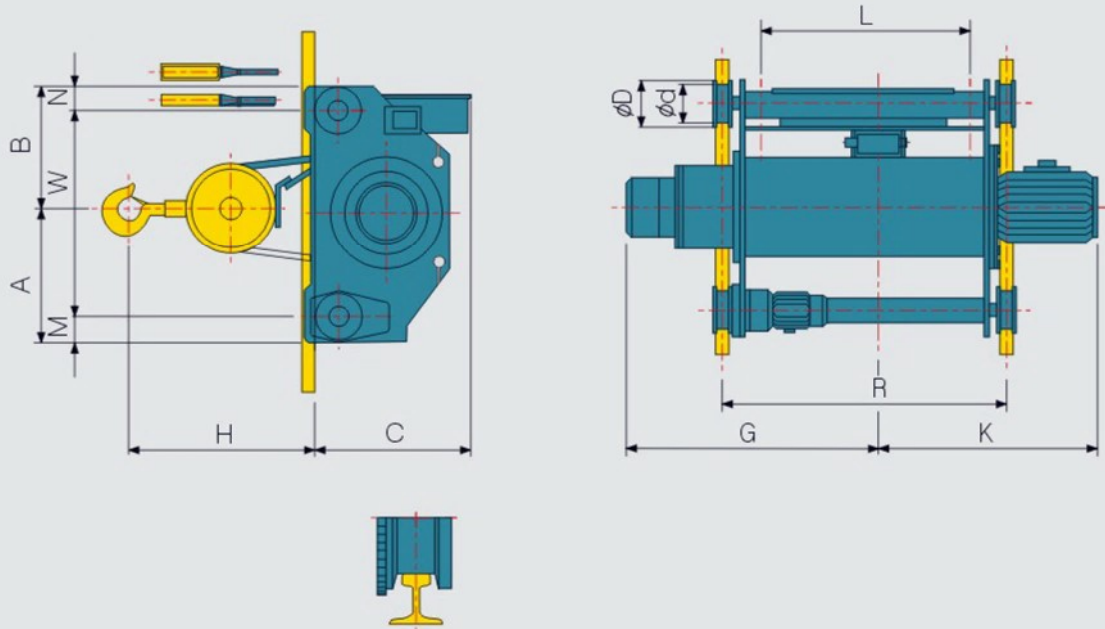

DAVIET CRANE & HOIST

## Tables of Dimensions

| Capacity (ton)                 |                          | 7.5                     | 10       | 15       | 20        | 30        |                   |
|--------------------------------|--------------------------|-------------------------|----------|----------|-----------|-----------|-------------------|
| Model                          |                          | KDWD 7.5                | KDWD 10  | KDWD 15  | KDWD 20   | KFD 30    |                   |
| Hoisting Lift (m)              |                          | 12                      | 12       | 12       | 12        | 12        |                   |
| Hoisting                       | Speed(m/min)             | High speed 50/60(Hz)    | 3.1/3.8  | 3.7/4.5  | 3.7/4.5   | 3.5/4.2   | 2.3/2.8           |
|                                |                          | Low speed 50/60(Hz)     | 2.3/2.8  | 2.5/3    | 2.5/3     | 2.3/2.8   | 1.5/1.8           |
|                                | Motor(KwXP)              | High speed              | 5.5 X 6  | 9 X 8    | 13 X 8    | 17 X 8    | 17 X 8            |
|                                |                          | Low speed               | 4.2 X 8  | 6 X 12   | 8.5 X 12  | 11.5 X 12 | 11.5 X 12         |
| Brake                          |                          | D.C Magnetic Disc Brake |          |          |           |           |                   |
| Traversing                     | Traversing Speed (m/min) | High speed 50/60(Hz)    | 12.5/15  | 12.5/15  | 12.5/15   | 12.5/15   | 12.5/15           |
|                                |                          | Low speed 50/60(Hz)     | 8.3/10   | 8.3/10   | 8.3/10    | 8.3/10    | 8.3/10            |
|                                | Traversing Motor (KwXP)  | High speed              | 0.75 X 4 | 0.75 X 4 | 1.5 X 4   | 1.5 X 4   | 1.5 X 4 (2 Units) |
|                                |                          | Low speed               | 0.75 X 6 | 0.75 X 6 | 1.0 X 6   | 1.0 X 6   | 1.0 X 6 (2 Units) |
| Wire rope DIA(mm) No. Of Falls |                          | 14φ X 4                 | 16φ X 4  | 20φ X 4  | 22.4φ X 4 | 22.4φ X 4 |                   |
| Approx. Dimensions(mm)         | H                        | 730                     | 775      | 995      | 1175      | 1790      |                   |
|                                | R                        | 1150                    | 1150     | 1200     | 1300      | 1800      |                   |
|                                | A                        | 525                     | 565      | 625      | 670       | 940       |                   |
|                                | B                        | 480                     | 510      | 555      | 615       | 940       |                   |
|                                | C                        | 550                     | 670      | 850      | 870       | 935       |                   |
|                                | G                        | 935                     | 975      | 1075     | 1165      | 1425      |                   |
|                                | K                        | 835                     | 955      | 1005     | 1195      | 1455      |                   |
|                                | W                        | 800                     | 865      | 920      | 1000      | 1540      |                   |
|                                | L                        | 850                     | 850      | 870      | 935       | 1420      |                   |
|                                | M                        | 110                     | 110      | 130      | 140       | 180       |                   |
|                                | N                        | 95                      | 100      | 130      | 140       | 160       |                   |
| φd                             | 165                      | 165                     | 180      | 220      | 250       |           |                   |
| φD                             | 195                      | 195                     | 210      | 250      | 280       |           |                   |
| RAIL (kg/m)                    |                          | 15                      | 15       | 22       | 22        | 30        |                   |
| Approx.Weight(kg)              |                          | 900                     | 1200     | 1850     | 2300      | 3450      |                   |

[ 정밀수치를 요하는 연장은 당사에 사전 확인바랍니다. If minute dimension is required on the side. It should be informed to us in advance.